



09/07-08/12

KIA CEE'D I SW

Cat. No. **K/023**

e20

e20\*94/20\*0785\*00

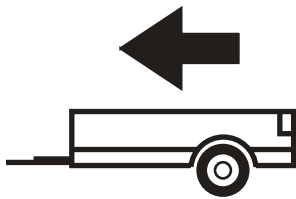

1600kg

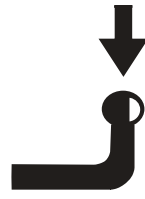

75kg

**D = 8,85kN**

D (kN) =



MAX kg x MAX kg

x 0,00981



MAX kg + MAX kg



IMIOLA HAK-POL

96-111 KOWIESY, CHOJNATA 23A, POLAND

Tel. + 48 46 831 73 31, fax +48 831 74 29

e-mail: office@imiola.pl, www.imiola.pl

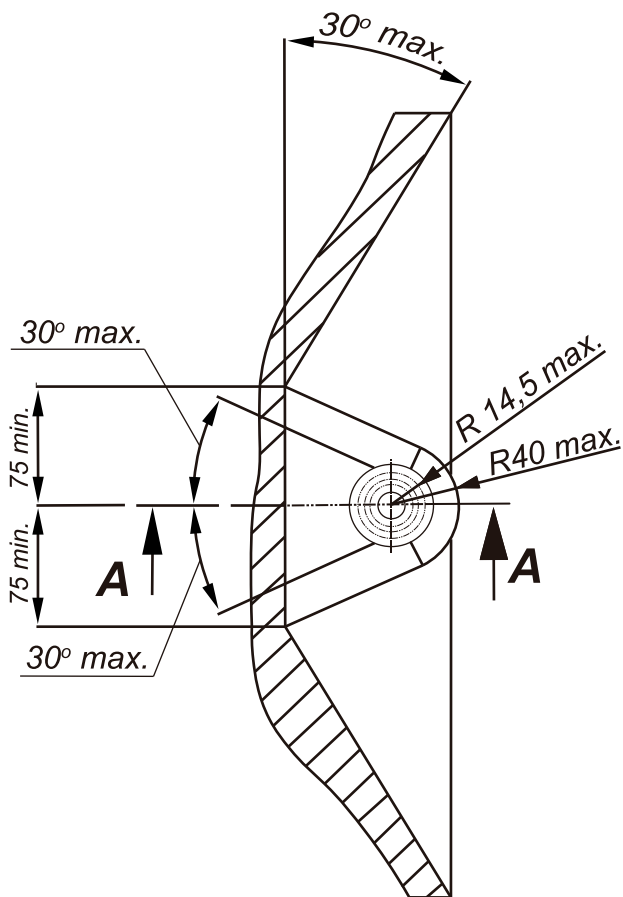

## PRZEKRÓJ A-A

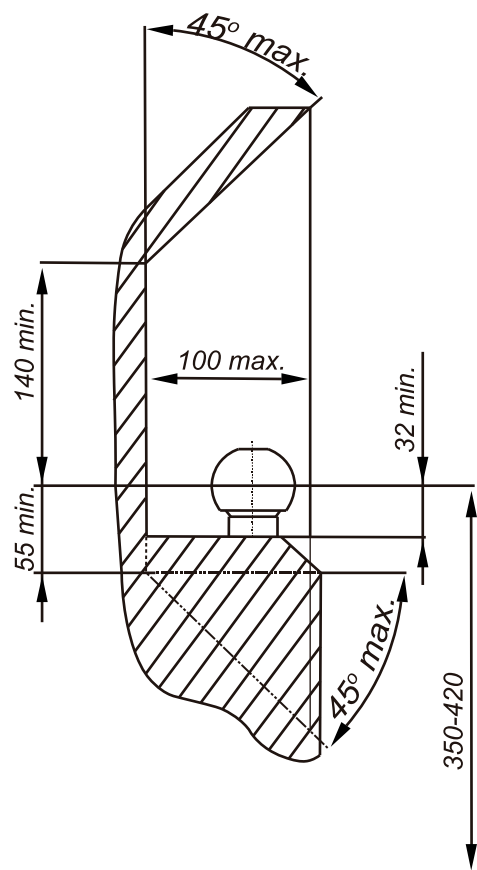

**PL** Należy zagwarantować przestrzeń swobodną według załącznika VII, rysunek 25a/b Regulaminu EKG ONZ 55.01 przy dopuszczalnym ciężarze całkowitym pojazdu.

**F** L'espace libre doit être garanti conformément à l'annexe VII, illustration de la réglementation 55.01 CE pour un poids total en charge autorisé du véhicule.







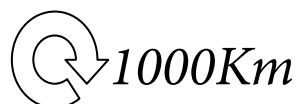

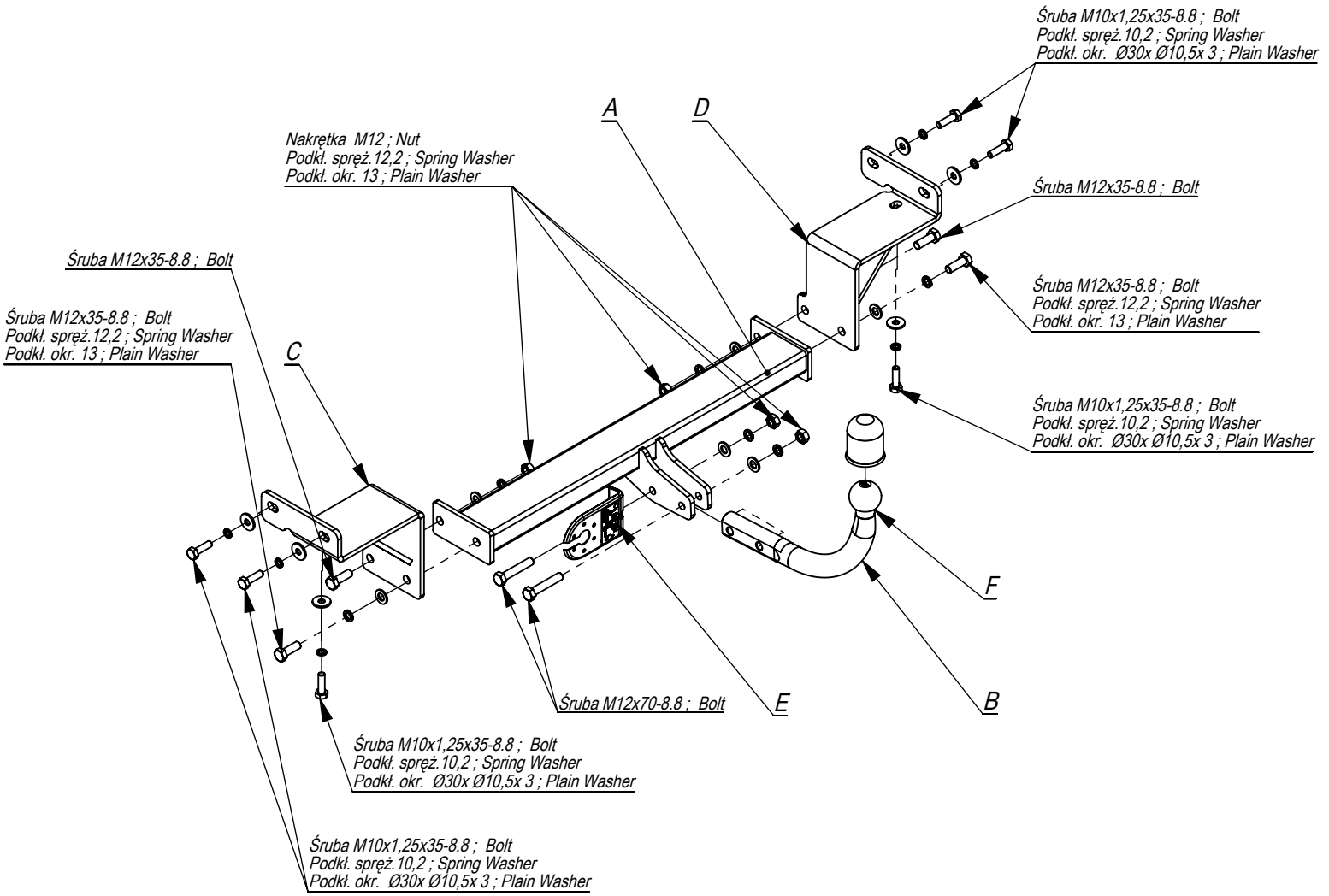

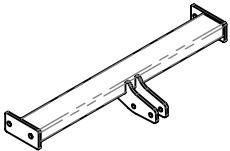
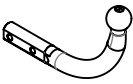
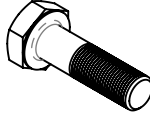
**GB** The clearance specified in appendix VII, diagram 25a/b of Regulation No. 55.01 UN EU must be guaranteed at laden weight of the vehicle.

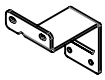
**D** Der Freiraum nach Anhang VII, Abbildung 25a/b der Vorschriften 55.01 EG ist zu gewährleisten bei zulässigem Gesamtgewicht des Fahrzeuges.

Moment skręcający dla śrub i nakrętek (8.8) Torque settings for nuts and bolts (8.8)	
M8	25Nm
M10	55Nm
M12	85Nm
M14	135Nm
M16	195Nm





	A	x1		B	x1		M12x70	2
							M12x35	4
							M10x1,25x35	6
	C	x1		D	x1		M12	4
							Ø30xØ10,5x3	6
	E	x1		F	x1		13	6
							10,5	6

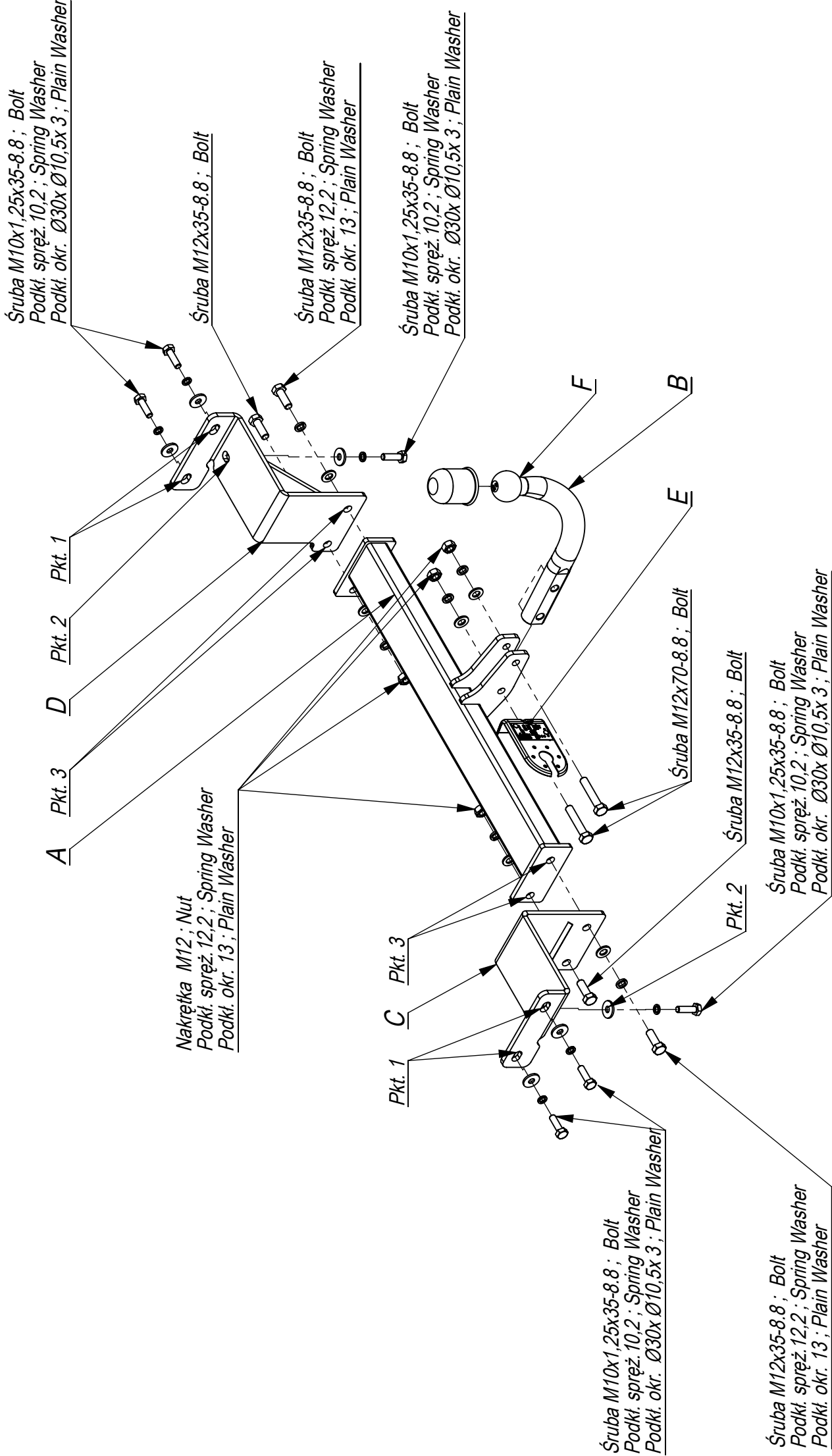

96-111 Kowiesy, Chojnata 23 A  
 tel. +48 46 831 73 31

Nr katalogowy K/023  
 Marka KIA Cee'd combi  
 od 2007 ->

- Odkręcić plastikowe osłony podłużnic.
- Opuścić tłumik.
- Udzielić technologiczne otwory z gwintami w podłużnicach.
- Przykręcić elementy C i D do podłużnic śrubami M10x1,25x35 wg rys. (pkt 1, 2).
- Do elementów C i D przykręcić belkę zaczepu A śrubami M12x35 8.8 (pkt 3).
- Dokręcić wszystkie śruby z momentem wg tabeli.
- Wykonać wycięcia w plastikowych osłonach podłużnic, a następnie przykręcić je.
- Założyć tłumik.
- Przykręcić kulę i blachę gniazda elektrycznego.
- Podłączyć instalację elektryczną.

- Unscrew the plastic shields of the metal clamps.
- Lower the damper.
- The technological holes with threads in the metal clamps make permeable.
- Screw the elements C and D to the metal clamps with bolts M10x1,25x35, according to the drawing (point 1, 2).
- Screw the main bar A to the elements C and D with bolts M12x35 8.8 (point 3).
- Tighten all the bolts according to the torque setting- see the table.
- Make an openings in the plastic shields of the metal clamps and next screw them.
- Hang the damper.
- Fix the ball and electric plate.
- Connect the electric wires.

- Desserrer les carters en plastiques de longerons.
- Abaisser le silencieux.
- Déboucher les trous technologiques avec le letage dans les longerons.
- Visser les éléments C et D aux longerons, en utilisant les boulons M10x1,25x35 selon le dessin (point 1, 2).
- Visser la poutre du crochet A aux éléments C et D à l'aide des boulons M12x35 8.8 (point 3).
- Serrer tous les boulons avec un couple de serrage selon tableau.
- Faire une coupe dans les carters plastiques des longerons et ensuite les serrer.
- Monter le silencieux.
- Visser la boule et socle de prise électrique.
- Raccorder le circuit électrique.

- Den Plastikschatz der Längsträger abschrauben.
- Den Ausputopf aus der Aufhängung absenken.
- Die vom Werk aus in den Längsträgern vorhandenen Önungen mit den Gewinden durchlässig machen.
- Die Tragteile C und D an die Längsträger mit den Schrauben M10x1,25x35 nach der Zeichnung (Punkt 1,2) anschrauben.
- An die Tragteile C und D, den Querbalken A mit den Schrauben M12x35 8.8 (Punkt 3) anschrauben.
- Alle Schrauben mit dem in der Tabelle angegebenen Drehmoment festziehen.
- In dem Plastikschatz der Längsträger Ausschnitte ausführen und sie anschrauben.
- Den Ausputopf einbauen.
- Die Kugel und die Steckdosenhalterung anschrauben.
- Die Elektroinstallation anschließen.

- Desenrosque las cubiertas de plástico de la parte inferior del parachoques.
- Baje el silenciador de la suspensión.
- Limpiar los orificios tecnológicos roscada en los largueros.
- Fijar los elementos C y D del gancho a los largueros con tornillos M10x1,25x35, 8.8 (punto 1,2).
- Atornillar la viga de la bola de remolque A a los elementos C y D usando tornillos M12x35 8.8 (punto 3).
- Apretar todos los tornillos con el par según la tabla anterior.
- Recorta el fragmento en la parte inferior del parachoques de acuerdo al patrón.
- Fijar el silenciador.
- Apretar la bola y la placa de la toma eléctrica.
- Conectar la instalación eléctrica.

